

QuickStart Setup Guide

Legal Warning

System Requirements



Logitech digital video security camera products are intended to be used in a lawful manner. Please note that certain uses of security camera products are prohibited or severely restricted by national, state and local laws, such as employee monitoring, surreptitious viewing and recording of images or sound, or the use, publication or distribution of image and sound recordings. Before using Logitech digital video security camera products you should become familiar with all applicable laws in your country. If you have any concern about certain uses of our products, kindly consult local authorities or local legal counsel.

Below, you can find the minimum and recommended requirements for systems running cameras using the default QVGA (320x240) settings. Running your cameras in the higher VGA (640x480) mode may require additional resources.

The WiLife Video Security System uses your Windows PC to record the video from your cameras and serve video to your remote devices. You need to have your PC on and running for the Wilife system to operate.

Master System Components



- 1) Outdoor Camera
- 2) USB Receiver Module
- 3) Overhang/Wall Mount
- 4) USB cable
- 5) Install CD includes:
 - WiLife Software
 - User's Manual

Computer Firewall Troubleshooting

When the WiLife Command Center first runs, you may be prompted by your firewall to allow WiLife to access the network. You should always answer, "Yes." This allows WiLife to communicate with the cameras and remote devices.

Requirement	Number of Cameras					
	1	2	3	4	5	6
CPU Speed: Recommended	2.2 GHz	2.4 GHz	2.6 GHz	2.8 GHz	3.0 GHz	3.2 GHz
Memory (MB): Recommended	512	512	512	768	1024	1024
Video Card (MB): Recommended DirectX 9 compatible	32	32	64	128	128	256
Display Resolution:	1024 x 768 or higher, 32 bit color					
Hard Drive (MB):	100 MB for program and a minimum of 500+ MB for video storage.					
Operating System:	Microsoft® Windows® Vista™ or Microsoft® Windows® XP Home Edition XP Professional or XP Media Center Edition					
Media Player:	Microsoft Windows Media® Player 9 or later					

* Intel® Pentium 4 CPU speed. Dual-core Intel and AMD processors deliver similar performance at lower clock speeds.

**Microsoft Vista requires more memory to deliver equal performance.

Outdoor Master System™

Congratulations on purchasing the WiLife Video Security System, an easy, professional, and complete digital security system that gives you the power to monitor what matters most to you.

With this Starter Kit, you have all of the components for a complete, professional-grade digital video surveillance system. This kit features the Outdoor Camera, which provides superior image quality and video performance. It also includes features like HomePlug networking, motion-based recording & alerts, and remote viewing. The Outdoor camera is weatherproof and suitable for most climates.

This QuickStart Setup Guide will assist you in installing and setting up your own digital video surveillance system. Simply follow these instructions and you will be viewing live video from your Outdoor Camera in minutes.

Build a Complete Surveillance System

The WiLife Video Security System is available online at www.wilife.com and at other select retail stores and authorized resellers. Visit www.wilife.com to find a store or reseller near you.



Add-on Indoor Camera



Add-on Outdoor Camera



Add-on Spy Camera

Step 1 Run the Setup Wizard

Please read all instructions before starting the installation. We encourage you to exit all other programs.

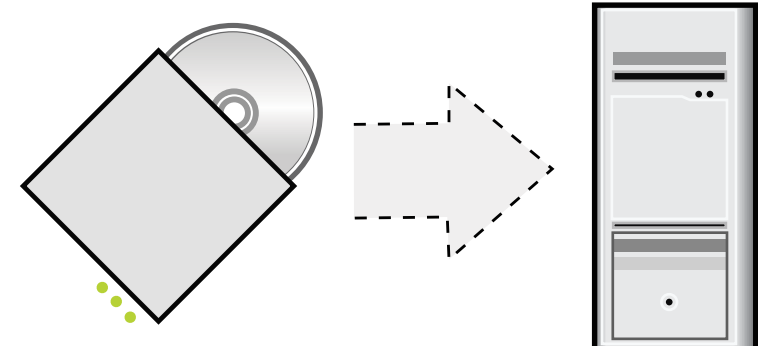

- Insert the WiLife Install CD.
- Click on the option "Install WiLife Software."
- Continue following the instructions on each screen of the InstallShield Wizard.

Step 2 Plug in USB Receiver

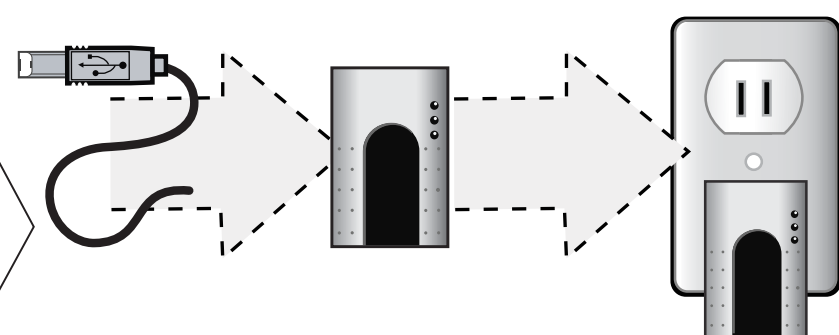

- When you see the "Plug in Receiver" screen, plug one end of the USB cable into the USB Receiver. Plug the USB Receiver into the wall plug.

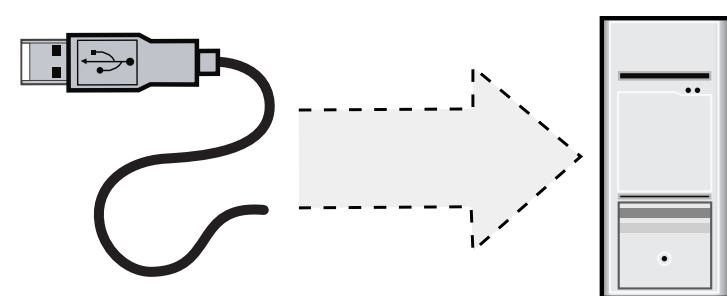

- Connect the USB cable from the USB Receiver to the USB port on your PC.

Step 3 Secure the Outdoor Camera

- The overhang/wall mount allows you to easily fasten your Camera to the roof or outside wall. Start by disassembling the mount and pre-drilling holes into the wall. Then follow these steps:
- Screw the base into the overhang or wall, using anchors if necessary.

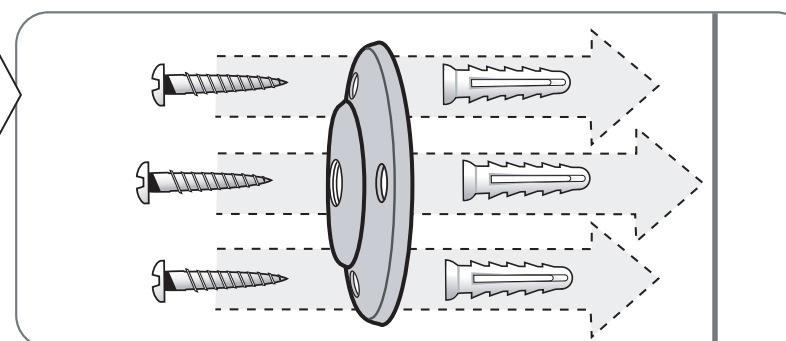

- Screw the coupler and extension into the base.

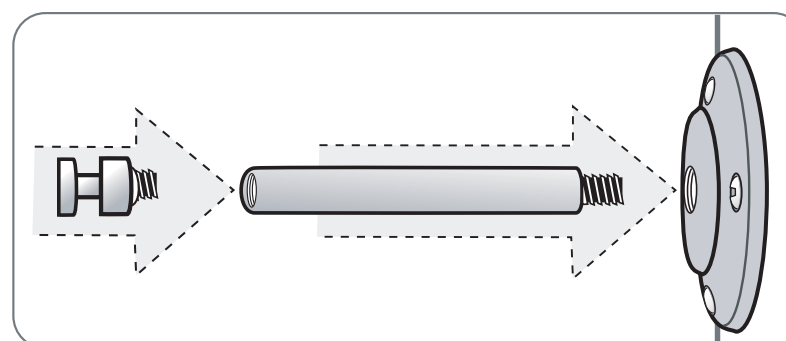

- Screw the pivot head into the top (or bottom) of the camera.

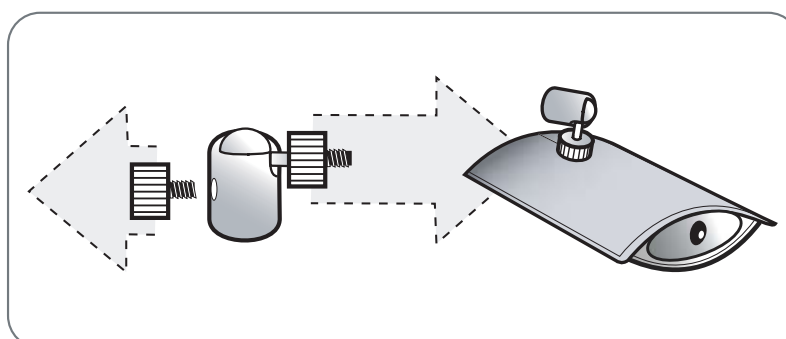

Camera mounting instructions cont'd...

- Place the pivot head into the coupler.

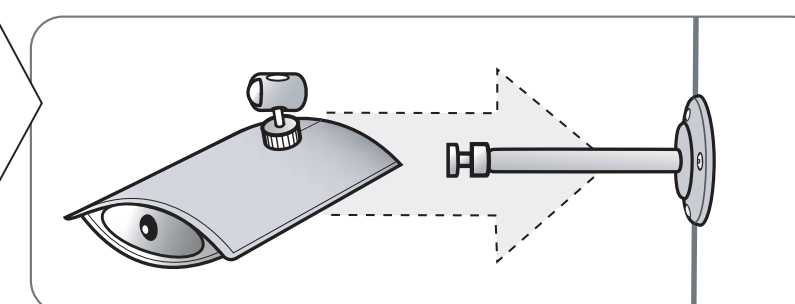

- Position the angle of the camera, and tighten the fastening screw to keep the angle you want.

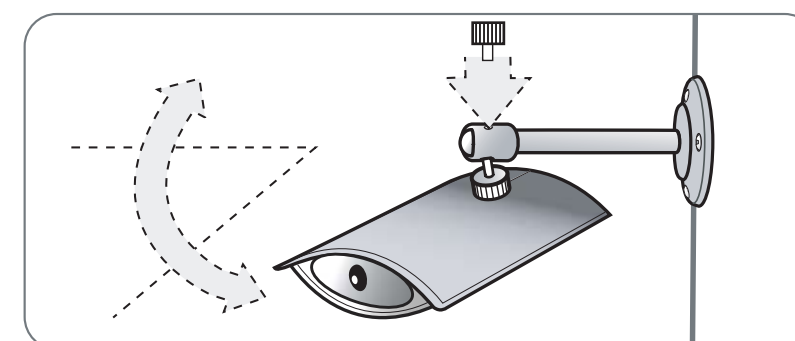

- Plug the camera into the nearest outlet.

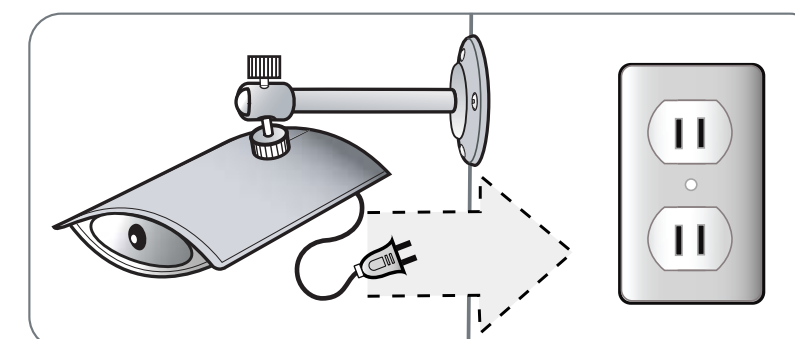

Notes:

- If the Wizard does not automatically load, manually start the Wizard by running the setup.exe file on the CD.
- The Wizard checks to see if Microsoft® .NET framework exists on your PC. If Microsoft.NET is not currently installed on your PC, the InstallShield Wizard will install it for you. If the Installer has to load .NET, you will need to restart Windows after .NET is installed.

Caution:

- To ensure a quality connection, do NOT plug the USB Receiver into a surge protector or powerstrip. The USB receiver already has built-in surge protection, and must be plugged directly into your wall outlet.

Most Popular Logitech WiLife Features

1 Changing Screen Views in WiLife



There are two main screens in the WiLife Command Center software, Live and Playback. Click the GO TO PLAYBACK button to open the Playback screen. Click the GO TO LIVE button to go back to the Live View screen.

The SETUP button opens the Setup dialog screens that allow you to modify settings for your cameras.

The WiLife button opens www.wilife.com.

2 Automatic Recording



WiLife automatically records video when cameras detect motion.

Recorded video segments are saved as .wmv files on your pc's hard drive.

You can find and play back the recorded video segments on the Playback screen.

8 Remote Viewing by PC

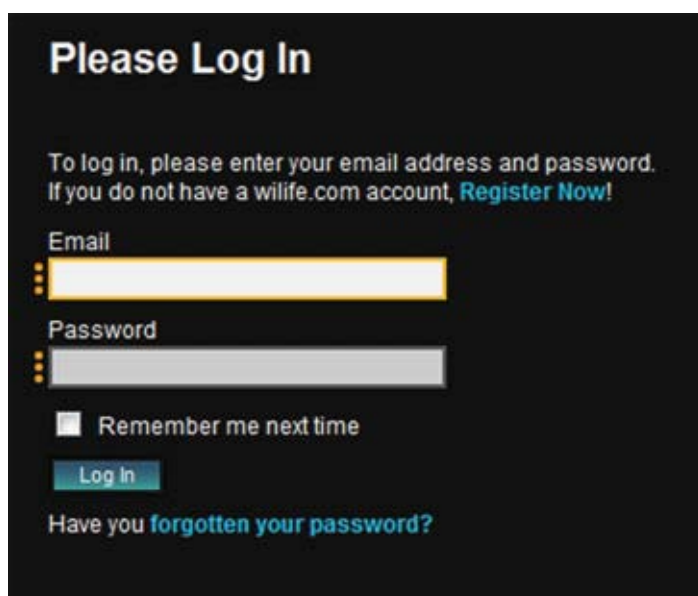

Log into WiLife Online at online.wilife.com and you can access live video from your cameras anywhere in the world, at any time. WiLife automatically determines your system's firewall settings and Internet capability in order to stream video to you in the most direct way possible. If WiLife cannot find a direct path, we send the video through our own WiLife servers to you. Now that's hassle free service!



3 View Recorded Video Clips



The Video Timeline window provides fast access to recorded video segments using the mouse or keyboard. Each camera has a row on the screen. Each recorded segment is displayed as a green bar. A vertical red line shows the current position of playback.

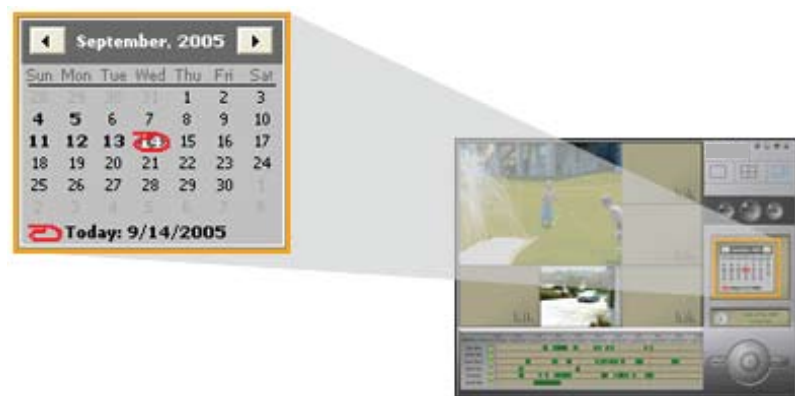

The Calendar shows you days that cameras recorded video. The current day is circled in red. Days in which video segments were recorded appear in bold. You can click on any of those days to display all of the video segments in the timeline. The Calendar has arrow buttons at the top to navigate forward or backward through the months.

4 Using the Playback Controls

Like any DVD player, the Playback Controls allow you to play, pause, adjust speed, and step-through your video segments. You use the controls by clicking on each one. If you hold your mouse over the control, Windows will display a tool tip, indicating the name of each control.

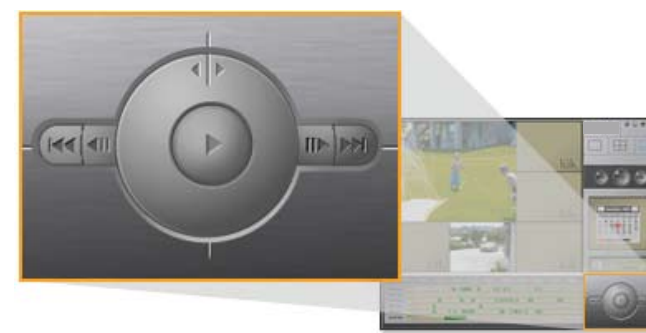

5 Email and Cell Phone Alerts

Receive email and cell phone alerts (messages) when a camera detects motion.

You have the option of receiving one of three message types:

- simple text-only
- text and one frame of video, or
- a video clip.

Go to Setup > Email to set up and activate e-mail and cell phone alerts.



6 Using Motion Detection Zones

By default, each camera automatically records video anytime it detects motion. However, WiLife Cameras also allow you to change from "entire image" motion detection to individually defined zones. In fact, you can set up to 16 distinct motion detection regions. This is useful, for example, if you want to monitor a parking lot and eliminate the detection of traffic along the road.



The settings that you have the ability to control include:

- Turning on/off motion detection
- Setting the motion sensitivity level
- Setting up to 16 detection zones
- Activating the entire image as one detection zone

Motion detection functionality can be set up in the Setup > Recording tab screen.

7 Easily Add More Cameras

You can have up to a total of six WiLife Cameras on your system, allowing you to cover the entire property. Additional cameras can be purchased in the Easy Add-on camera kits for the Indoor, Outdoor, or Spy cameras. Adding new cameras is a simple three-step process:

1. Have your WiLife Software system running.
2. Position the camera on a window, desktop, or wall (using the mounting options available) and connect to the WiLife Power Supply.
3. If you set a custom password, click Setup > Advanced and click Find My Cameras. It will take WiLife 1 to 2 minutes to locate the camera.

9 Remote Viewing by Cell Phones



Using a Windows Mobile® enabled wireless PDAs or cell phones, log into WiLife Online at online.wilife.com and you can access live video from your cameras anywhere in the world, at any time.

WiLife automatically determines your phone's bandwidth in order to stream video to you in the most direct way possible. If WiLife cannot find a direct path, we send the video through our own WiLife servers to you. Now that's hassle free service!

11 Upgrade to WiLife Platinum



Upgrade to WiLife Platinum™ and expand your already powerful WiLife Video Security System™ with enhanced monitoring, remote play back, digital pan-tilt-zoom, scheduled alerts, and online video storage.

Adding the advanced capabilities of WiLife Platinum gives you more power and flexibility to protect your property, family, and employees — providing you with the ultimate in video security. Learn more at online.wilife.com.

Product Help

For camera & command center setup instructions, and general screen & feature overviews, please refer to the User Guide located on the Software CD or by pressing the F1 key in Command Center.

For troubleshooting tips, view the User Guide located on the Software CD.

Software updates and other user documentation can be found online at www.wilife.com/support/downloads.

Technical Support

Setup is designed to have your system and cameras running in a few minutes. However, if you are experiencing difficulties or have questions, please contact us. Our support team is available. We have online and phone support to make your setup easy.

Go to <http://www.wilife.com/support> for immediate support. You can email our support team or view help information in our Knowledgebase.

For live support, call our support number: 1.888.469.4543

For customers within the United States and Canada.

10 Online System & Camera Updates

Num	Camera Name	Camera Type	Current Version	New Version	Select	Status
1	Engineering	WiLife Indoor Camera	2.17	2.19	<input checked="" type="checkbox"/>	Programming, 2%
2	Lower Entry	WiLife Indoor Camera	2.17	2.19	<input checked="" type="checkbox"/>	Programming, 2%
3	Lower West	WiLife Indoor Camera	2.17	2.19	<input checked="" type="checkbox"/>	Programming, 2%
4	Hallway	WiLife Indoor Camera	2.17	2.19	<input checked="" type="checkbox"/>	Programming, 2%
5	Upper East	WiLife Indoor Camera	2.17	2.19	<input checked="" type="checkbox"/>	Transferring, 50%
6	Upper West	WiLife Indoor Camera	2.17	2.19	<input checked="" type="checkbox"/>	Transferring, 71%

WiLife will automatically check the software version dates and prompt you to download the latest version. Go to Setup > Advanced and click on Update Camera to accomplish this.

Summary of Limited Product Warranty

Logitech warrants that your Logitech hardware product shall be free from defects in material and workmanship for one (1) year, beginning from the date of purchase. Except where prohibited by applicable law, this warranty is nontransferable and is limited to the original purchaser. This warranty gives you specific legal rights, and you may also have other rights that vary under local laws. Remedies: Logitech's entire liability and your exclusive remedy for any breach of warranty shall be, at Logitech's option, (1) to repair or replace the hardware, or (2) to refund the price paid, provided that the hardware is returned to the point of purchase or such other place as Logitech may direct with a copy of the sales receipt or dated itemized receipt. Shipping and handling charges may apply except where prohibited by applicable law. Logitech may, at its option, use new or refurbished or used parts in good working condition to repair or replace any hardware product. Any replacement hardware product will be warranted for the remainder of the original warranty period or thirty (30) days, whichever is longer or for any additional period of time that may be applicable in your jurisdiction. This warranty does not cover problems or damage resulting from (1) accident, abuse, misapplication, or any unauthorized repair, modification or disassembly; (2) improper operation or maintenance, usage not in accordance with product instructions or connection to improper voltage supply; or (3) use of consumables, such as replacement batteries, not supplied by Logitech except where such restriction is prohibited by applicable law. How to Obtain Warranty Support: Before submitting a warranty claim, we recommend you visit the support section at www.logitech.com for technical assistance. Valid warranty claims are generally processed through the point of purchase during the first thirty (30) days after purchase; however, this period of time may vary depending on where you purchased your product – please check with Logitech or the retailer where you purchased your product for details. Warranty claims that cannot be processed through the point of purchase and any other product related questions should be addressed directly to Logitech. The addresses and customer service contact information for Logitech can be found in the documentation accompanying your product and on the web at www.wilife.com/support. Limitation of Liability: LOGITECH SHALL NOT BE LIABLE FOR ANY SPECIAL, INDIRECT, INCIDENTAL OR CONSEQUENTIAL DAMAGES WHATSOEVER, INCLUDING BUT NOT LIMITED TO LOSS OF PROFITS, REVENUE OR DATA (WHETHER DIRECT OR INDIRECT) OR COMMERCIAL LOSS FOR BREACH OF ANY EXPRESS OR IMPLIED WARRANTY ON YOUR PRODUCT EVEN IF LOGITECH HAS BEEN ADVISED OF THE POSSIBILITY OF SUCH DAMAGES. Some jurisdictions do not allow the exclusion or limitation of special, indirect, incidental or consequential damages, so the above limitation or exclusion may not apply to you. Please review the complete Limited Warranty at www.wilife.com/support/warranty.

© 2009 Logitech. All rights reserved. Logitech, the Logitech logo, and other Logitech marks are owned by Logitech and may be registered. All other trademarks are the property of their respective owners. Logitech assumes no responsibility for any errors that may appear in any manual or on this website. Information contained herein is subject to change without notice.